

# SEBRIGHT MODEL 5060

## ENERGY EFFICIENT COMPACTOR

2.5 CUBIC YARD CAPACITY



This compactor is specially designed for **high volumes** of trash. Its **high packing force** and **deep ram penetration** into the container does a superior job of reducing bulky waste and trash to a fraction of its original volume.

- Abrasive resistant floor (AR 235)
- Large clear top opening 51" x 58"
- Large cylinder (6" bore, 4 1/2" rod)
- Deep container penetration, full 16"
- Highly visual oil sight gauge with thermometer

- Underwriter Laboratories listed components
- Long motor life (T.E.F.C)
- Exact alignment pump/motor mount C-face)
- Automatic full/Jam shut off

### *Ideal for.....*

Offices  
Motels/Hotels  
Hospitals  
Chain Stores  
Restaurants  
Warehouses  
Truck Terminals

And other commercial and light  
Industrial refuse generating locations

Call Toll Free

**1-800-253-0532**

---

**Sebright Products, Inc.**

127. N Water St.

Hopkins, MI 49328

[www.sebrightproducts.com](http://www.sebrightproducts.com)



## The Densification Specialists

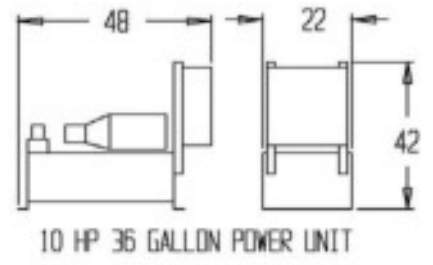
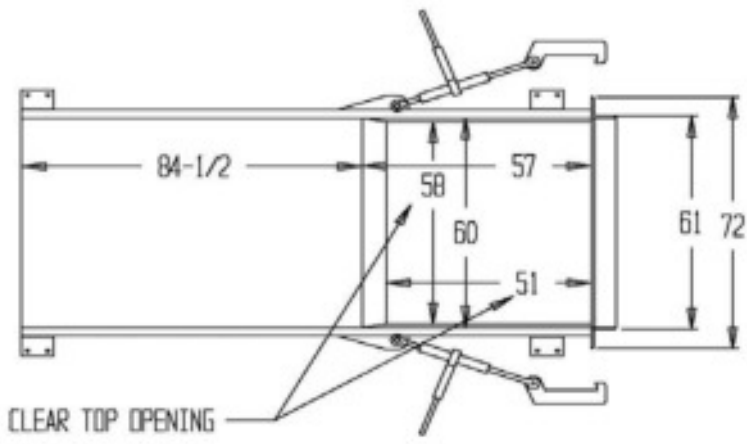

10 HP 36 GALLON POWER UNIT

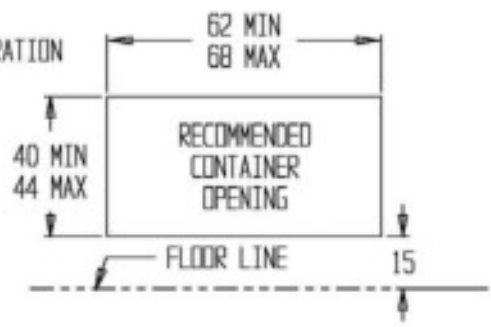
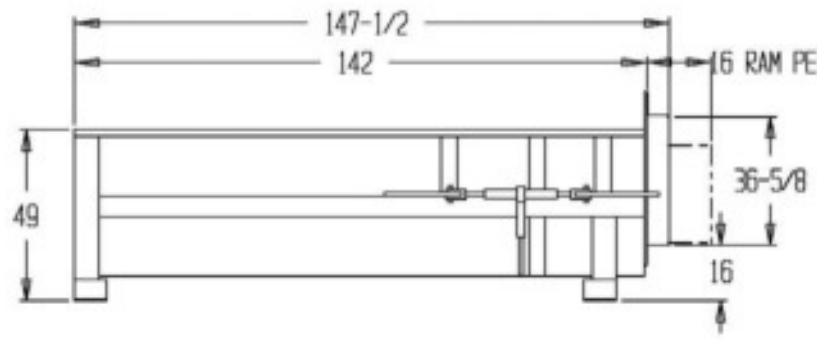

Model Number	Cu. Yd.	Motor H.P.	Pump GPM	No. of Cyls.	Cyl. Bore	Cyl. Stroke	Max PSI	Ram Face Sq. In.	Ram Face PSI	Cyl. Force	Cycle Time	Cu. Yd. Hour	Hyd. Res. (Gal)	Base Unit Weight (lbs)
5060-1-6	2.5	10	16	1	6	68	2,000	1,590	36	56,550	45	142	36	5,090
5060-HV-1-6	2.5	15	19	1	6	68	2,000	1,590	36	56,550	38	169	36	5,176

Note: Sebright power units feature tri-voltage motors, 208/230/460 volt 3 phase (please specify). For 208 volt applications a 10 hp/12 gpm or 15hp/16 gpm motor and pump combination is recommended. Special power units are also available for 230 volt single phase. Approx. Base unit weight includes reinforced Breaker Bar with long retainer teeth.

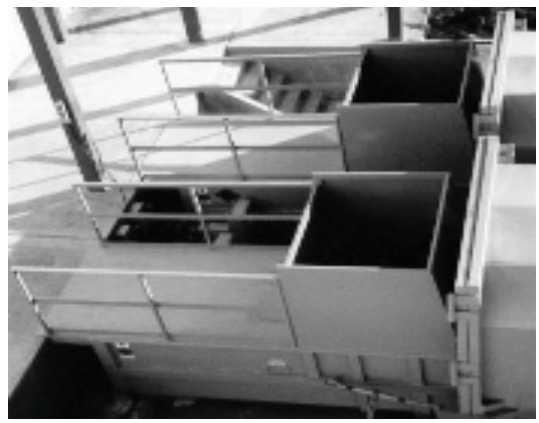

Due to product improvements, the manufacturer reserves the right to alter, or amend, without notice, any of these specifications and/or dimensions.

All machines and accessories are primer coated and finished painted. Standard color chart available upon request.



**Sebright Products, Inc.**  
 127 N. Water St., Hopkins, MI 49328  
 Phone: 269/793-7183 - Fax: 269/793-4022  
 Toll Free 800-253-0532  
 www.sebrightproducts.com

**Complete line of Dry & Wet Waste Equipment Including:**  
 Stationary Compactors \* Self-Contained Compactors \* Precrushers \* Hydraulic Dumpers \* Densifiers \* Construction Compactors  
 High Density Extruders \* Belt Filter Presses