

SEBRIGHT MODEL 4860

2.0 CUBIC YARD CAPACITY STATIONARY COMPACTOR

This compactor can fit into tight spaces (116½") using the same premium components as featured in our larger compactor. This proven design provides the life expectancy and performance that is the trademark of a Sebright Compactor.



Options Shown:

Right hand security chute, deck mounted power unit with cover. Pressure Boost System (hauler's station) with keyed override.

STANDARD FEATURES

- Abrasive resistant floor (AR 235) alloy
- Industrial ram guide system
- Large cylinder (6" bore, 4½" rod)
- 36 gallon hydraulic reservoir
- Long-life totally enclosed fan cooled motor (T.E.F.C)
- Remote station with container full light
- Liquid filled pressure gauge
- 15 ¼" of ram penetration

Call Toll Free
1-800-253-0532

Sebright Products, Inc.
127 N. Water St.
Hopkins, MI 49328



The Densification Specialists

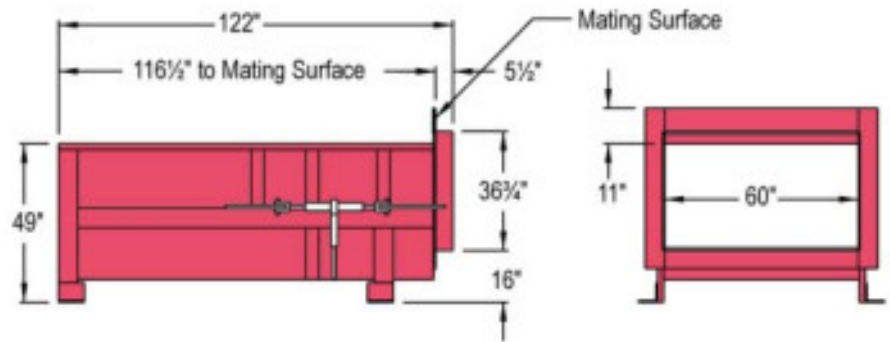
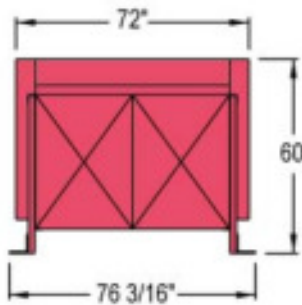
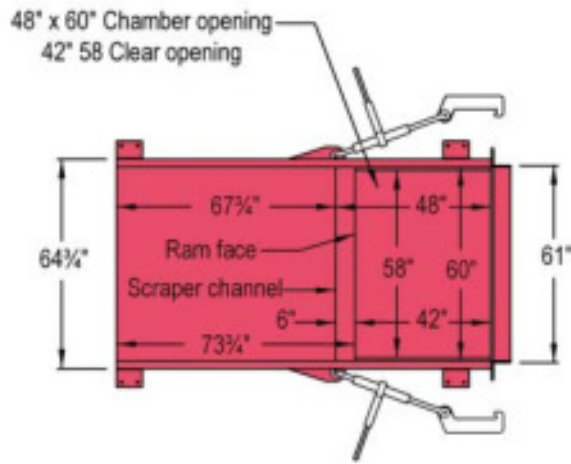
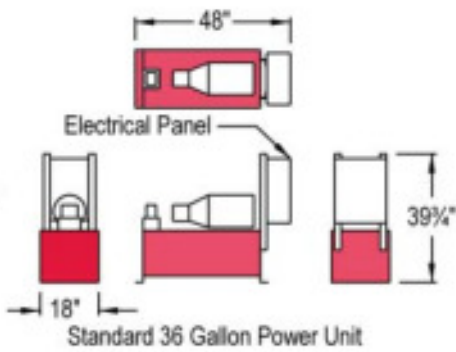

Model 4860 Specifications

Model Number	Cu. Yd.	Motor HP	Pump GPM	No. of cyls.	Cyl. Bore	Cyl. Stroke	Max PSI	Ram Face Sq. In.	Ram Face PSI	Cyl. Force	Cycle Time	Cu. Yd. Hour	Ind. Criteria Rating	Base Unit Weight (lbs)
4860	2.0	10	12	1	6	58	2000	1,590	35.6	56,540	51	101	1.43	4,500



CONTROL

The operator station features Allen Bradley safety key lock, pull to start, push to stop switch with full container light; and can be mounted in any convenient location



POWER UNIT

The 10 hp power unit features brand name components: Vickers hydraulics, Baldor T.E.F.C. motor, Allen Bradley controls and a NEMA 4 electrical enclosure - all standard!



Sebright Products, Inc.
 127 N. Water St., Hopkins, MI 49328
 Phone: 269/793-7183 - Fax: 269/793-4022
 Toll Free 800-253-0532
 www.sebrightproducts.com



VICKERS



BALDOR

Due to product improvements, the manufacturer reserves the right to alter, or amend, without notice, any of these components, specifications and/or dimensions.

All machines and accessories are primer coated and finish painted. See standard color chart for available color selections.

Complete line of Dry & Wet Waste Equipment Including:

Stationary Compactors * Self-Contained Compactors * Precrushers * Hydraulic Dumpers * Densifiers * Construction Compactors
 High Density Extruders * Belt Filter Presses * Conveyors