

SEBRIGHT MODEL 3860-1-6 STATIONARY COMPACTOR



STANDARD FEATURES

- *Short overall length*
- *Abrasive resistant alloy floor (AR235)*
- *44 Gallon hydraulic reservoir for long oil life*
- *6" Bore & 4.5" rod cylinder*
- *Reinforced breaker with hinged retainer teeth*
- *13" of Ram Penetration*
- *Remote operator's control station with safety keylock*

The Model 3860-1-6 stationary compactor was designed to fit ***tight spaces, measuring 92.5"*** from the mating surface to the rear of the unit. With a 32" x 60" charge chamber opening and time-tested durable straight-ahead 6" bore cylinder, this compactor can be used at commercial laundry plants, light industrial manufacturers, hotels, hospitals, colleges, schools, chain stores and outlet centers

The superior design and high quality workmanship of this unit along with its many standard features, make it your best value on the market today.

Call Toll Free
1-800-253-0532

Sebright Products, Inc.,
127 N. Water St.
Hopkins MI 49328



The Densification Specialists

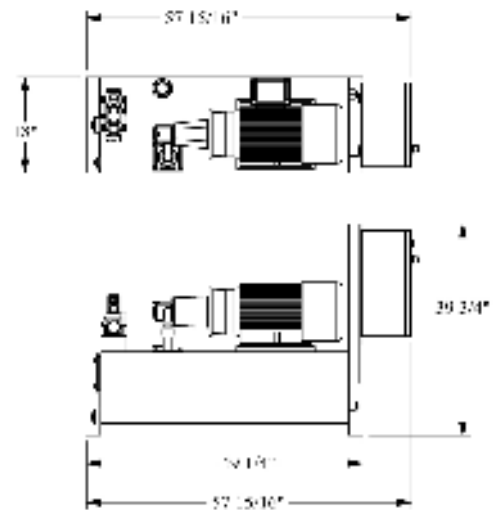
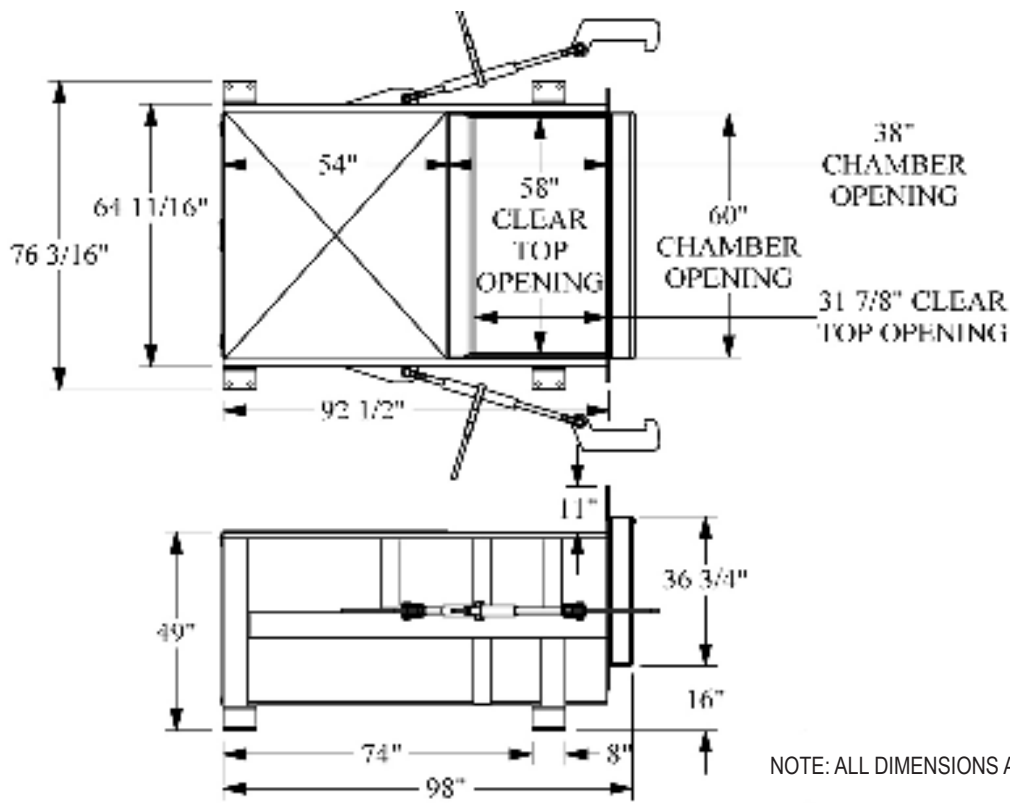

10 HP 44 Gallon Power Unit

NOTE: ALL DIMENSIONS ARE IN INCHES



Model 3860-1-6 Specifications

Model Number	Cu. Yd.	Motor HP	Pump GPM	No. of Cyls.	Cyl. Bore Inches	Cyl. Stroke (inches)	Max PSI	Ram Face Sq. In.	Ram Face PSI	Cyl. Force (lbs.)	Cycle Time (sec)	Cu. Yd. Hour	Ram Penetration (inches)	Base Unit Weight (lbs.)
3860-1-6	1	10	10	1	6	46	2,000	1,560	36	56,550	49	79	13	4,200



Sebright Products, Inc
 Phone: 269-793-7183
 Fax: 269-793-4022
 Toll Free: 800-253-0532
 www.sebrightproducts.com



While Sebright Products, Inc., strives to make the information provided on processing of your waste or recycling stream, as timely and accurate as possible, the company makes no claims, promises or guarantees about the accuracy, completeness, or adequacy of any of the provided information, and expressly disclaims liability of errors and omissions in the content of the information, or analysis provided to your company. It is solely the responsibility of each recipient of the information Sebright Products, Inc., has provided to satisfy itself as to the accuracy of the information provided by Sebright Products, Inc., and as to the efficacy of the product(s) for the use(s) intended.

Due to product improvement, the manufacturer, reserves the right to alter or amend, without notice, any of these specifications and/or dimensions.

All machines and accessories are primer coated and finish painted. Standard color chart is available upon request.

Complete Line of Solid & Wet Waste Handling Equipment includes:

Stationary Compactors * Self Contained Compactors * Precrushers * Hydraulic Dumpers * Densifiers * Construction Compactors * High Density Extruders * Belt Filter Presses * Xtractors * Conveyors * X³Cyclers * Oil Filter Recycler * X-Sizer

Copyright 2018-N